

# TECHNICAL DESIGN GUIDE



# HepvO<sup>®</sup>

## PLUMBING

### Hygienic Self Sealing Waste Valves

Prevents the escape of foul sewer air from waste discharge systems.

Actively maintaining a pressure equilibrium in soil and waste installations.

HepvO is a self sealing valve designed to close the waste connection below a sanitary appliance to prevent the escape of foul sewer air into the dwelling.

HepvO actively eliminates negative pressure within the waste system by opening and allowing in fresh air until a state of equilibrium with atmosphere is reached. This means that venting of the waste system, or the inclusion of air admittance valves in the waste system is no longer necessary.

The HepvO valve means enhanced plumbing design and system efficiency, without compromising performance or risking the



escape of foul air into the living space from the drain or sewer.

HepvO is a self sealing valve designed to close the waste connection below a sanitary appliance to prevent the escape of foul sewer air into the dwelling and thereby complies with the requirements of **BS 5572: 1994** Code of practice for Sanitary pipework and Document H of the Building Regulations 1985 'Drainage and Waste Disposal'. Extensive testing has shown that the HepvO valve performs under everyday conditions in which traditional water sealed traps are prone to failure.

The HepvO valve will perform under back pressures which are 10 times greater than those experienced in a typical soil and waste system.

## The HepvO Range - Product Selector

The HepvO valve can be installed vertically or horizontally (with an adaptor) and is available in 32mm and 40mm.

**Material:** Polypropylene **Colour:** White **Certification:** Watermark Certificate Number 042/97 - Revision 1, June 1998

**Universal Compression Outlet**

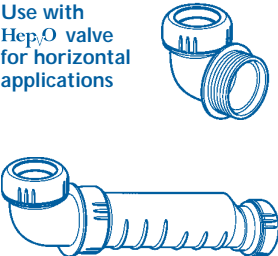
Nominal Diameter mm	32	40		Nominal Diameter mm	32	40		Nominal Diameter mm	32	40
HepvO Waste Valve				HepvO 87 1/2° Knuckle Adaptor				HepvO Running Adaptor		
Hygienic Self Sealing Waste Valve				Use with HepvO valve for horizontal applications				Use with HepvO waste valve when installing in a pipe run		
	✓	✓			✓	✓			✓	✓

## Foul Air: The importance of exclusion

It is a **mandatory requirement** of the Building Regulations (see Approved Document H.1) that a foul water drainage system shall be **adequate**. In the view of the Secretary of State the requirement of Approved Document H.1 will not be met if the drainage system does not **'prevent foul air from the drainage system from entering the building under working conditions'**.

Single stack soil and waste discharge systems, as described in **BS 5572: 1994 Code of practice for Sanitary pipework** will be subject to negative and positive pressures as water is discharged from associated sanitary appliances. These pressure fluctuations may result in self siphonage, induced siphonage or compression. Fig. No.'s 1, 2 & 3.

Fig. No. 1 Self Siphonage

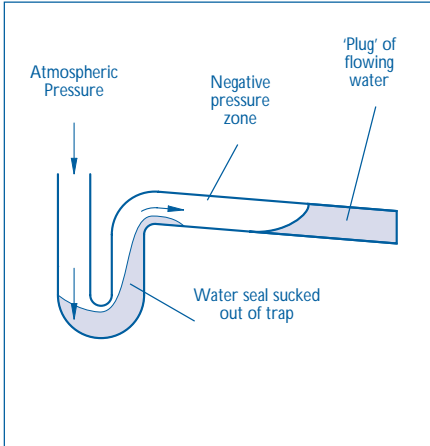

Fig. No. 2 Induced Siphonage

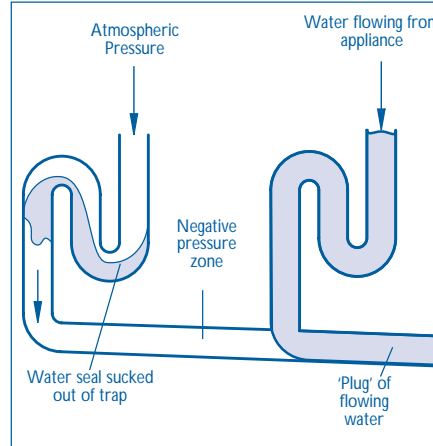
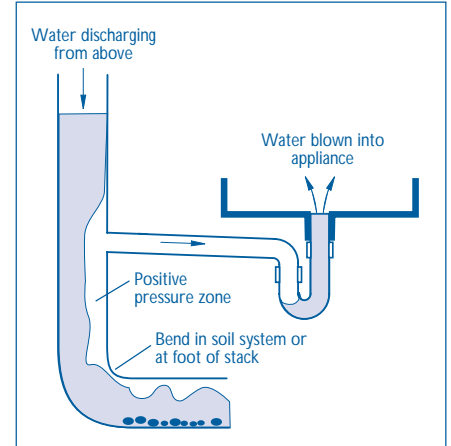

Fig. No. 3 Compression



If the single stack system is designed **strictly in accordance** to the guidance in **BS 5572** then these positive and negative pressure fluctuations can cause water trap seal reduction, for example, reducing a wash hand basin trap from 75mm to 25mm. Systems which deviate from the regulations will be subject to greater pressure fluctuations which commonly result in *water displacement* out of the trap allowing foul air to enter the building.

Foul sewer air is undesirable and must not be tolerated. A water seal trap which is not protecting people from the entry of sewer air can be identified by either a **Gurgling Noise** and/or a **Foul Drain Smell**.

## Hep<sub>v</sub>O : A Barrier between the Living Space and the Drainage System

The Hep<sub>v</sub>O self sealing valve opens under the water pressure of an appliance emptying and closes to form a tight seal after the appliance has discharged under normal atmospheric conditions Fig. No. 4.

Fig. No. 4 Operation of Hep<sub>v</sub>O

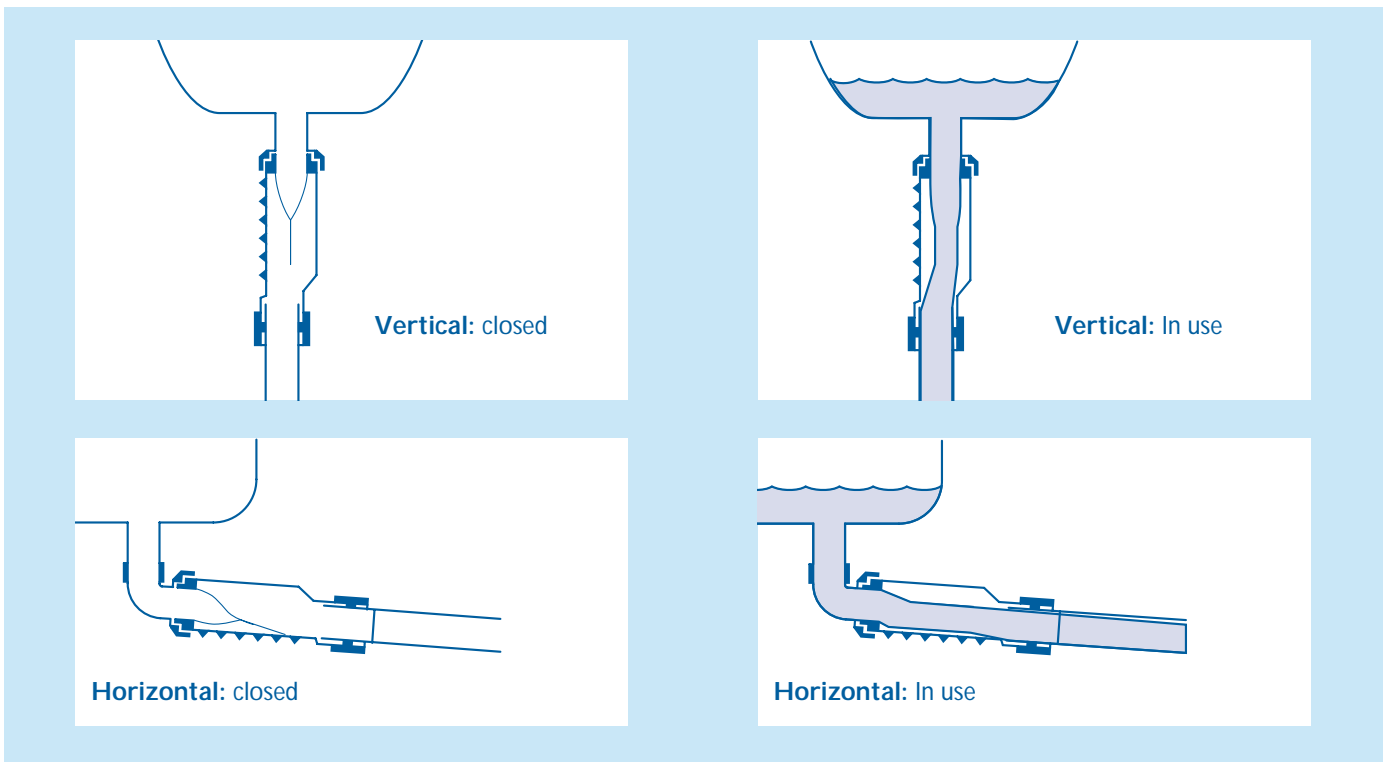

## HepvO - Design and Performance - continued

The performance of the valve in excluding foul air is **unaffected** by those pressures normally found in domestic and commercial soil and waste systems. HepvO removes the risk of the escape of foul sewer air, that exists when using conventional traps, and exposure to environments which can be polluted by foul sewer air, entering through the waste system. In addition HepvO will not tolerate or support microbial growth of a fungal, bacterial or viral nature.

Excessive positive pressures will be relieved by air bubbles escaping through any WC water seal within the system. However should *abnormally excessive* internal pressures exceed 500mm water gauge (0.5 bar) then the valve element of HepvO will invert indicating system failure. This would allow water to backfill the appliance, thereby giving an *important safety warning* that blockage of the drainage system had occurred, in much the same manner as a traditional trap.

## HepvO - Applications

HepvO actively eliminates negative pressure within the waste system by opening and allowing in fresh air until a state of equilibrium with atmosphere is reached.

More commonly, in the case of negative pressures the HepvO valve is designed to open in order to equalise negative pressures by admitting fresh air into the system, and subsequently closing to reseal the waste system and prevent foul air release.

Where there is a waste branch which enters the stack above the WC branch, HepvO will provide an air inlet and no air admittance valve is required.

The *dual function* that the HepvO valve performs in:-

- (i) preventing the entry of foul sewer air
- (ii) actively eliminating negative pressure

means that **venting** of the waste system, in a single stack soil system, is *no longer necessary* and the practice of fitting **Air Admittance Valves** to a soil and waste system is also *unnecessary*.

Note: Care should be taken to ensure that the underground drainage system is not completely sealed. Natural open ventilation is required at the head of each main drain run and/or at every tenth dwelling.

### HepvO in the Bathroom

Typically, house designs are becoming more creative and complex to meet the needs of today's specifiers, in doing so they create greater potential within the system for pressure fluctuations and trap failure.

*Example:* Adjacent bathroom and en-suite

In this design (Fig. No. 5) a conventional water seal trap would be liable to failure as a result of pressure fluctuations. Use of the HepvO valve in this design would relieve negative pressure changes and maintain an effective seal between each waste appliance and the drainage system.

Fig. No. 5 **Problems leading to Trap failure within a typical Bathroom and Ensuite Arrangement**  
Installation requirements often dictate pipework is outside the design limitations of BS 5572

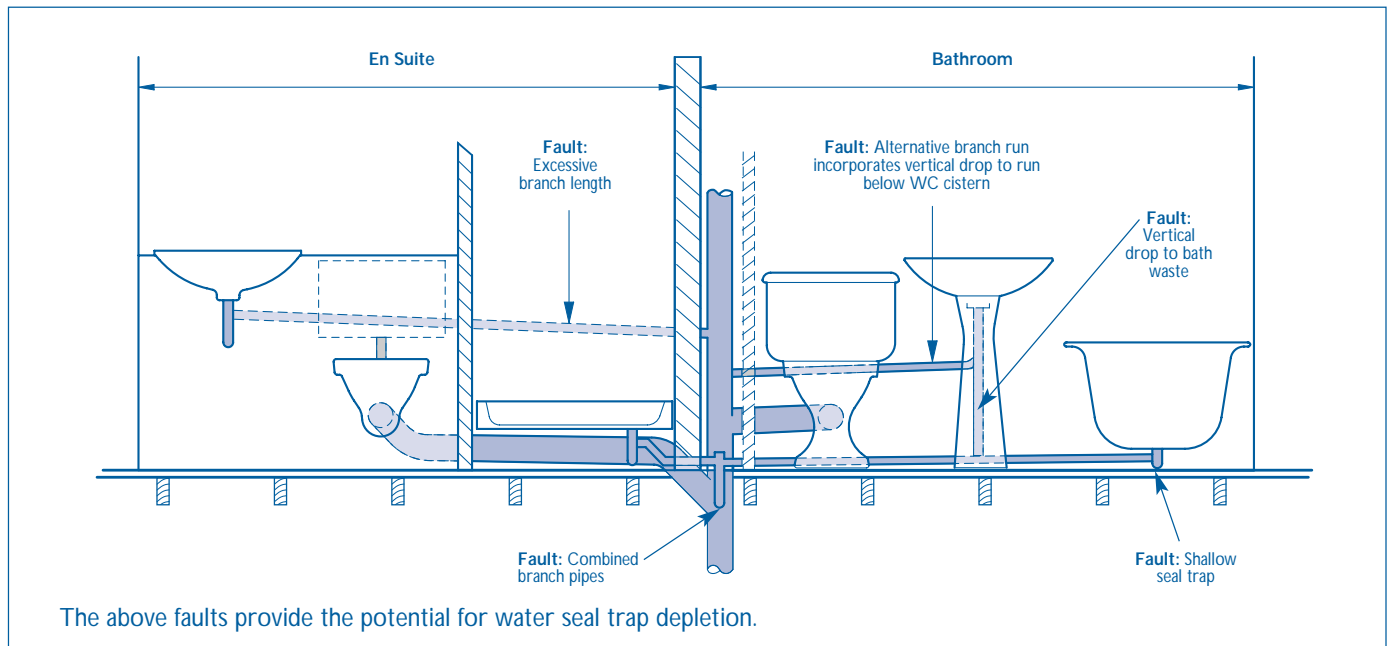

### HepvO Standards and Approvals

HepvO when installed in accordance with manufacturers recommendations will ensure that installations comply with the requirements of BS 5572: 1994 Code of practice for Sanitary pipework and Document H of the Building Regulations 1985 'Drainage and Waste Disposal' with respect to seal integrity.

HepvO functions without the use of water, and complies with all other relevant functional requirements of BS 3943: Specification for plastics waste traps.

HepvO is certified by WIMLAS; certificate number 042/97, to be a satisfactory means of excluding foul air from a building within a single stack drainage system.

**BBA Certification is applied for.**

# HepvO - Benefits

## Water Seal Weaknesses

The HepvO valve does not rely on water to protect the dwelling from the entry of foul sewer gases and will not fail under any of the conditions shown below in Fig. No. 6.

Fig. No. 6 10 Potential Reasons for Trap failure

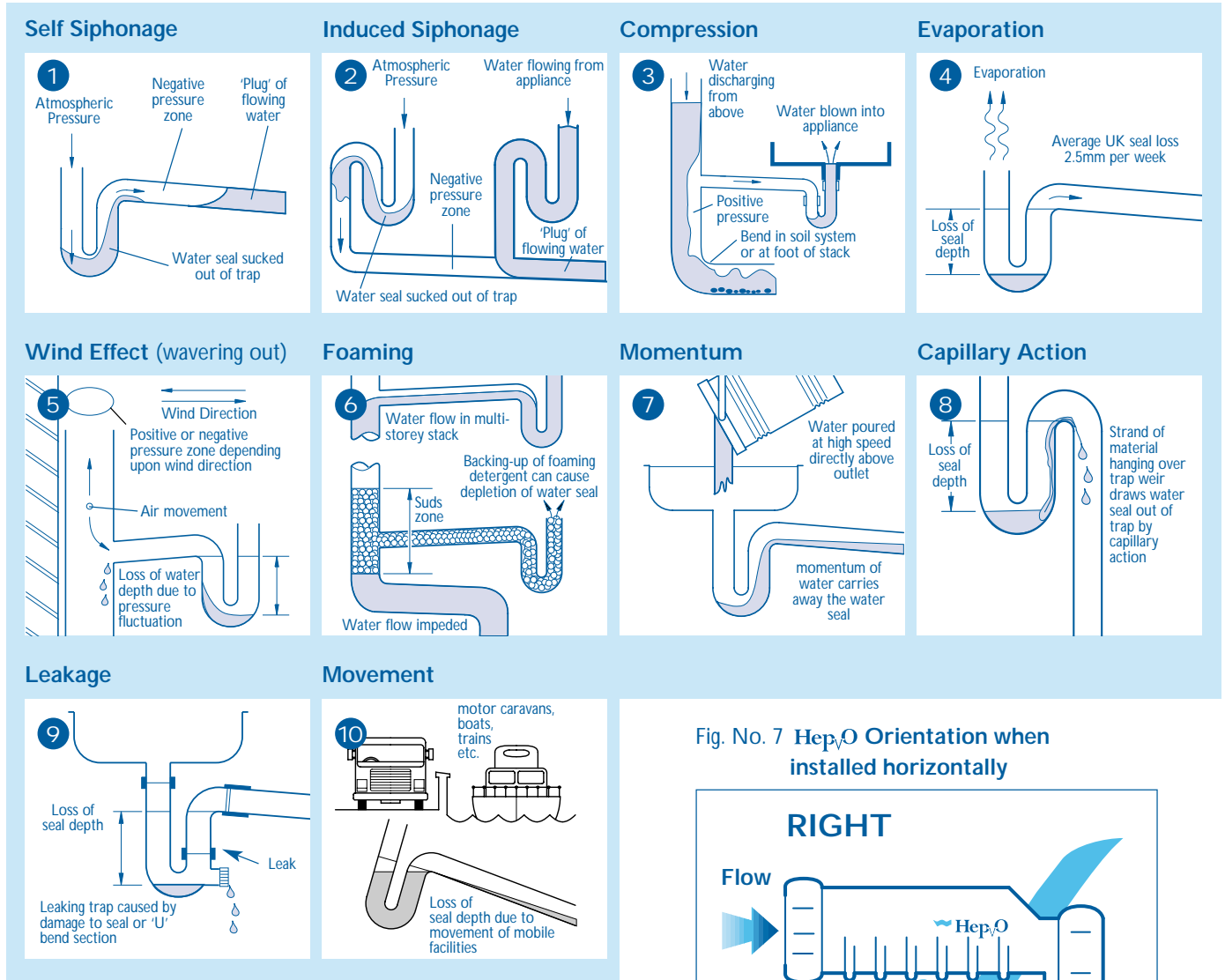
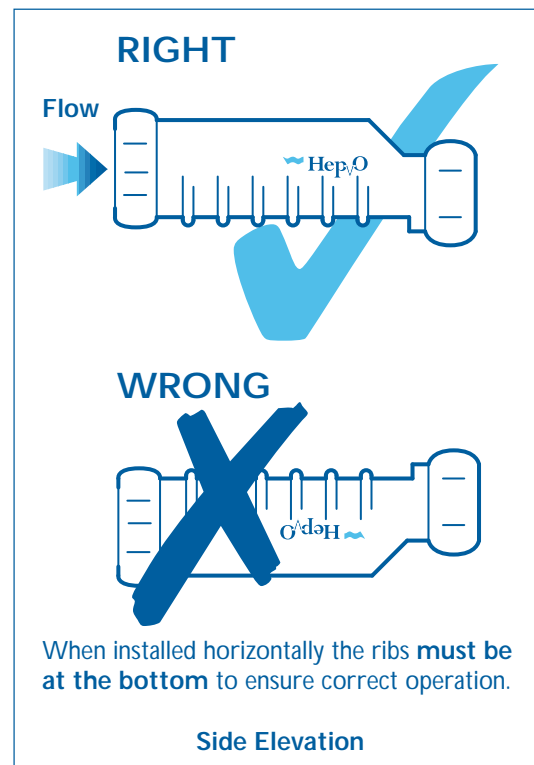

Fig. No. 7 HepvO Orientation when installed horizontally



# HepvO - Sitework

## HepvO Inlet

The inlet is provided with a screwed cap, flanged tail and sealing ring, which are designed to connect to waste fittings conforming to BS EN 274, or BS 3380, or to a HepvO inlet adaptor.

## Fixing

When fixed horizontally to an appliance outlet or to a sloping pipe, in order to prevent standing water and to provide a continuous fall, HepvO must be installed with the ribs underneath - Fig. No. 7.

# HepVO - Sitework - continued

Offer up the HepVO inlet to the threaded tail of the waste pipe and tighten the threaded cap by hand (check that the cap screws on square and does not 'cross-thread'), hand tight should be adequate. When the screwed cap is tight, proper seating should be obtained, and the HepVO body should be secure.

## HepVO Outlet

The outlet is provided with a universal compression connection which is designed for use with **BS 5254** Polypropylene pipe, **BS 5255** ABS, MUPVC or polypropylene pipe, **BS 2871: Part 1:** Table X copper pipe, or equivalent imperial size copper pipe to **BS 659**.

## Fixing

- 1 Cut the pipe to length, allowing for the full compression socket depth, (preferably using an appropriate pipe cutter).
- 2 Remove any 'swarf' from the end of the plastic pipe. Ream the copper pipe end to remove any 'burr', and file if necessary to remove any external sharp edges. Mark the socket depth on the pipe, and check that the pipe section to be jointed is free of any surface damage which may affect the joint seal.
- 3 Unscrew the cap from the HepVO outlet, and slide the cap and rubber seal onto the pipe. Fig. No. 8.
- 4 Insert the pipe end fully into the socket.
- 5 Slide the rubber seal and screwed cap up against the face of the socket, and tighten the cap by hand, (check that the cap is square to the body and does not 'cross-thread'), hand tight should be adequate to form a proper seal.

**N.B DO NOT USE ANY JOINTING COMPOUND OR SEALANT ON THE HepVO INLET OR OUTLET CONNECTIONS.**

Fig. No. 8 HepVO Outlet Connection

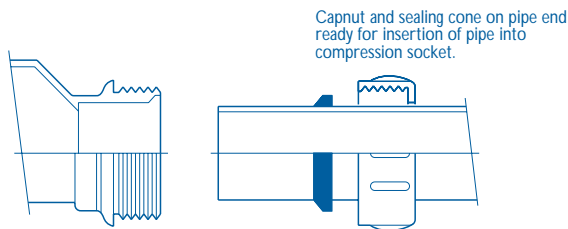
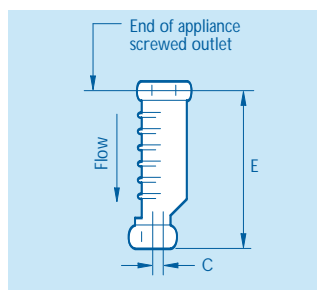

Fig. No. 9 Dimensional Data

## Principal Dimensions

Size	C	E	L	W	Z
32mm	8	171	208	211	40
40mm	5	171	208	213	40



a) Fixed vertically directly to appliance outlet

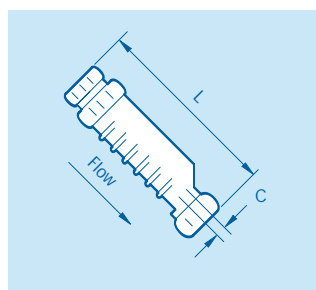

b) Fixed on a pipe at any sloping angle using inlet adaptor Cat. No. BV3 or CV3 (available separately)

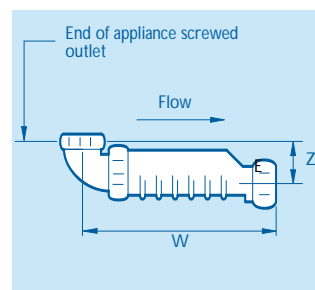

c) Fixed horizontally to appliance outlet using inlet bend adaptor Cat. No. BV11 or CV11 (available separately)

## Application

HepVO can be used on any waste appliance, the installation arrangement will depend on the dimensional design of the appliance and site constraints. Fig. No. 10 shows some of the mounting options for HepVO.

Fig. No. 10 HepVO Mounting Options

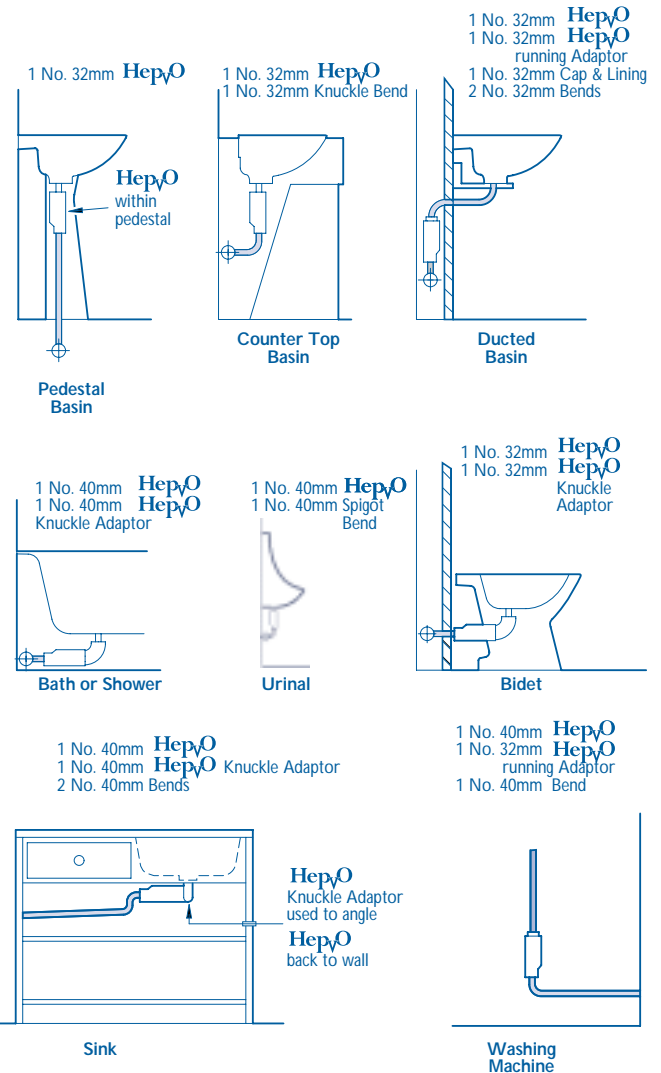

HepVO can be fixed directly to the waste outlet of an appliance, or by using the appropriate adaptor, mounted in the horizontal position either at the appliance or on the pipe.

HepVO may be installed at any angle between vertical and horizontal.

## Notes

- 1 Dimensions are nominal and may vary slightly due to compression of the rubber seals.
- 2 When fixed to a pipe, it is recommended that HepVO should remain accessible.

## HepVO - Sitework - continued

Waste pipes should have sufficient slope to convey the likely flow, but should not be less than 18mm/metre in accordance with **BS 5572**. When using HepVO, there is *no maximum slope limitation* which is often a restriction applicable to single stack waste systems.

As HepVO is unaffected by siphonage or compression, *combined waste piping* can be used to connect more than one appliance to the stack. Fig. No. 11 shows how HepVO can be used to simplify the plumbing to the typical bathroom, previously shown in Fig. No. 5.

Fig. No. 11 HepVO Installation in a Typical Bathroom

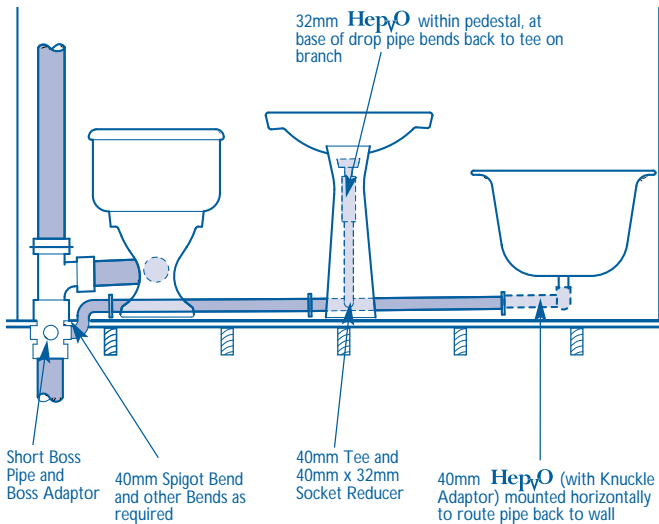

Any branch discharge pipes serving appliances not fitted with HepVO (eg. a range of W.C's) should be designed and installed in accordance with **BS 5572**.

Discharge stacks should continue to be sized, and vented where appropriate, in accordance with **BS 5572**.

## HepVO - Testing & Maintenance

The following tests are relevant to any sanitary installation, and are not only applicable to installations where HepVO is incorporated.

### Air Tests

Sanitary installations should be air tested to 38mm water gauge for at least 3 minutes, in accordance with Building Regulations Approved Document H. Installations which incorporate HepVO can be tested in the normal manner, using standard test equipment, as shown in Fig. No. 10. Various sizes of expanding pipe stoppers (100mm or larger) are available from the Hepworth drainage range. Smoke producing equipment should **not** be used when testing plastics pipework.

### Water Tests

Water testing the base of a discharge stack is recommended, especially where there are no appliances on the bottom storey, and where the stack is to be concealed. Testing is normally achieved by fixing a temporary expanding pipe stopper to the drain at the base of the stack, and filling the stack with water up to the flood level of the lowest sanitary appliance (providing that the test pressure does not exceed 6 metres water gauge for soil and waste products and 4 metres water gauge for drainage products). When performing a water test, it is recommended that the expanding pipe stopper is provided with a temporary strut (to prevent blow-out), and fitted with a drain valve.

Fig. No. 10 Tests Methods

### Method 1

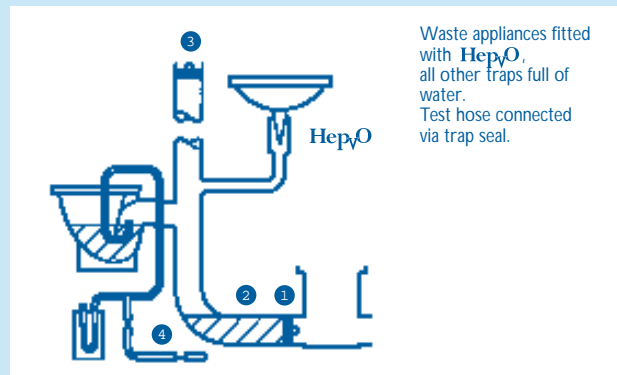

Waste appliances fitted with HepVO, all other traps full of water. Test hose connected via trap seal.

### Method 2

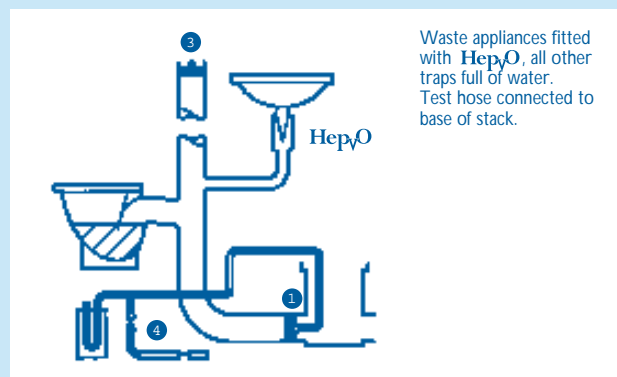

Waste appliances fitted with HepVO, all other traps full of water. Test hose connected to base of stack.

### Method 3

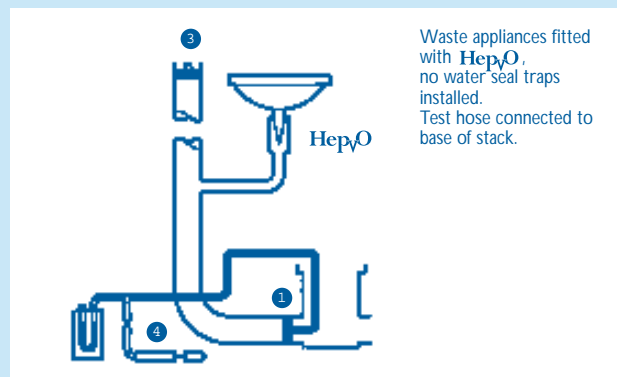

Waste appliances fitted with HepVO, no water seal traps installed. Test hose connected to base of stack.

### Key

- ① Temporary expanding pipe stopper in drain at the base of the stack.
- ② Water filled behind stopper to confirm effective seal (optional).
- ③ Temporary expanding pipe stopper in discharge stack (not necessary where air admittance valve is installed)
- ④ Standard air testing kit comprising of air pump, test cock, 'U' gauge, test hose and hose tee piece.

### Notes:

- a An inflatable bag type pipe stopper may be used instead of an expanding pipe stopper at ①, where appropriate.
- b On multi-storey buildings it may be more convenient to test the stack in stages.

## Performance Tests

Sanitary installations should be tested at simultaneous design flow conditions in accordance with **BS 5572**. Tests for self-siphonage and induced siphonage in branch discharge pipes

where Hep<sub>v</sub>O is fitted to each appliance are unnecessary. Other branch pipes and discharge stacks should be tested in accordance with Table 11 of **BS 5572**.

## What Does Hep<sub>v</sub>O Mean to the Professional Installer?

### Installation Benefits

Hep<sub>v</sub>O is a new concept in the prevention of foul air escaping into the building whilst actively eliminating negative pressure in soil and waste installations. It allows the designer to place a greater number of appliances together on fewer discharge pipes anywhere within the building without compromising the performance of the sanitary discharge system.

#### System Simplification - Design Freedom and Economic Benefits

Current regulations for waste system design set limits on length and gradient of pipes and the number of appliances which can be connected to a waste pipe in order to keep pressure fluctuations to a minimum, this may be rectified by the incorporation of vent pipes at appropriate design locations. The incorporation of Hep<sub>v</sub>O increases the designers scope for the reasons listed below, whilst providing a good sanitary system offering a minimum resistance to flow, as stated in **BS 5572: 1994 Code of Practice for Sanitary Pipework**.

- 1 Full bore flow will no longer cause siphonage where Hep<sub>v</sub>O is fitted to all appliances. Full bore flow provides better self cleansing which means that smaller diameter waste pipe branches can be considered in many applications.
- 2 Anti-siphon piping and valves are not required for waste appliances.
- 3 Auxiliary venting is not required for ranges of waste appliances.
- 4 No maximum limit on waste pipe slopes.
- 5 Branches connecting waste appliances to a common pipe do not need to be swept at 45 degrees.
- 6 Where necessary tight radius bends can be used, without fear of siphonage or compression.
- 7 Waste pipe configurations, such as parallel branches, will not cause siphonage or compression problems, therefore there is no need to increase pipe size.

#### System Simplification - Space Saving

Where required, the waste pipe can drop in a straight line from the appliance outlet which means that installation access for slimline pedestals is significantly enhanced - Fig. No. 12.

Fig. No. 12

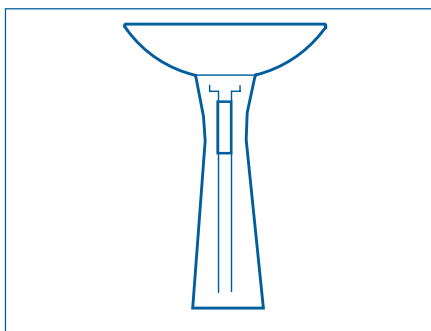

For kitchen sinks Hep<sub>v</sub>O can be offset to the back wall after a short run of waste pipe from the appliance outlet which opens up the cupboard space below the sink - Fig. No. 13.

Fig. No. 13

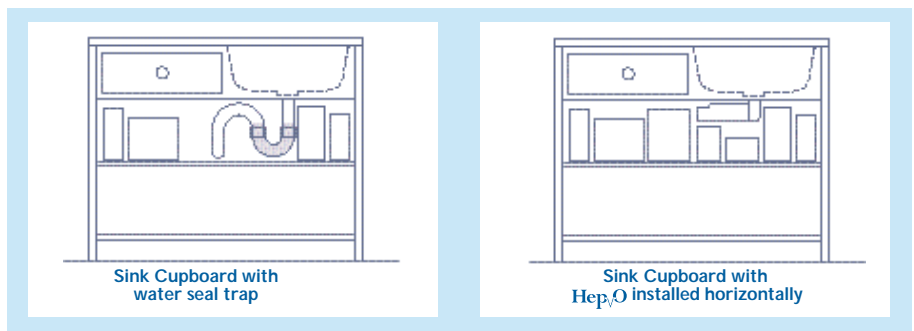

#### System Simplification - Time Saving

Hep<sub>v</sub>O allows for simpler systems with less pipework and straight runs - Fig. No. 14.

On completion of the installation, there is no need to perform self siphonage and induced siphonage tests for branch discharge pipes from waste appliances.

Fig. No. 14 Schematic View for 3 Basins

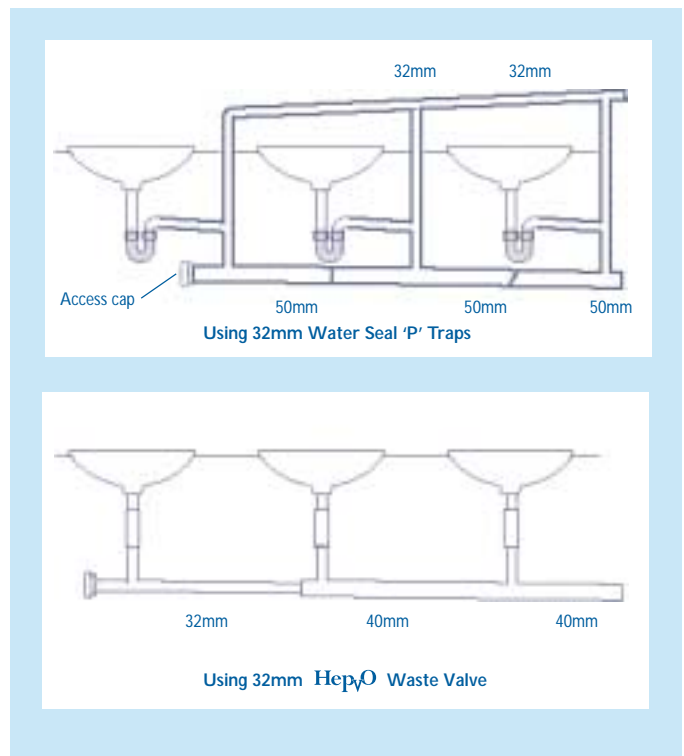

Hep<sub>v</sub>O can be installed horizontally, by using the 90° adaptor, which avoids cutting the floor under baths and showers to accommodate the 'U' bend of a trap - Fig. No. 10 & 11.

## Performance Benefits

Once installed HepvO offers considerable benefits over traditional water sealed traps.

### Hygiene - No Siphonage, No Noise, No Smells

HepvO is a dry sealing valve and unlike water seal traps is not affected by siphonage and will not therefore compromise the air within the dwelling environment.

HepvO operates silently and is not subject to 'gurgling' noises typically associated with Siphonage and indicative of a breach in the water seal barrier.

HepvO will not admit foul air into the building as it maintains an air tight seal and acts to relieve negative pressures normally responsible for water seal trap destruction.

The HepvO valve promotes hygiene, particularly where an appliance is infrequently used, since it does not hold water in a trap which can become stagnant with waste residue, emitting smells and enhancing bacterial growth, nor does it dry out - Fig. No. 16.

Fig. No. 16

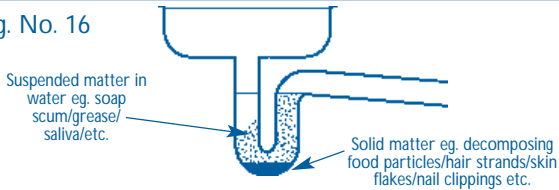

### Hygiene - No Leaks

HepvO has no water trap in which debris can collect or trap water freeze causing blockage or subsequent leakage.

If blockage occurs in the waste pipe, it is possible to rod the pipe from the appliance outlet with a plain ended rod - Fig. No. 15.

Fig. No. 15

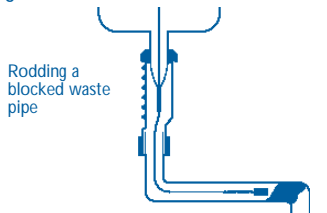

35 Rooks Road  
Nunawading, VIC 3131  
TEL (03) 9874 0303 FAX (03) 9874 0505

e-mail: [info@hepworthaustralia.com.au](mailto:info@hepworthaustralia.com.au)

web site: [www.hepworthaustralia.com.au](http://www.hepworthaustralia.com.au)

Hepworth Australia is a division of  
Exel Distributors Pty Ltd.

## Answers to Key Questions

### 1 Will HepvO promote better hygiene by stopping the escape of foul sewer air into habitable spaces?

YES - The HepvO valve has been proven to perform under conditions in which traditional water seal traps are vulnerable to failure. It will continue to perform under back pressures 10 times greater than those experienced in typical soil and waste systems.

### 2 Does the air tight seal break down if a strand of cloth or hair collects in the grating and falls down between the faces of the valve?

NO - the HepvO valve has undergone extensive foreign body testing (WIMLAS Certificate No. 042/97 - Revision 1, June 1998). Tests show that the HepvO valve will maintain an air tight seal around an obstruction such as hair, fabric strands or spaghetti.

### 3 What is the life expectancy of HepvO?

Current test results indicate that the HepvO valve has a life expectancy at least equivalent to current water sealed traps.

### 4 Is HepvO subject to limescale crustation?

NO - the flexibility of the HepvO valve seal prevents accumulation of limescale.

### 5 Will HepvO block easily?

NO - Extensive testing has shown that the HepvO valve is less prone to blockage than traditional water seal traps.

### 6 Will the seal be maintained even when the appliance hasn't been used for some time?

YES - The HepvO valve does not depend on a water seal and so it will continue to maintain a seal whether an appliance never gets used or is used very infrequently.

### 7 Can HepvO be used to protect a number of sanitary appliances in the same way as a running trap is used?

YES - However HepvO should be placed adjacent to the appliance as required by BS 5572.

### 8 Does HepvO comply with the requirements of the Building Regulations and BS 5572?

YES - HepvO is a self sealing valve designed to seal the waste connection below a sanitary appliance to prevent the escape of foul air into the building and thereby complies with the requirements of BS 5572 : 1994 Code of practice for Sanitary pipework and Document H of the Building Regulations 1985 'Drainage and Waste Disposal'.

### 9 What is the effect of hot and cold fat being discharged into the HepvO valve?

In tests the HepvO valve continues to perform and will maintain an air tight seal when not discharging an appliance. In comparative tests with conventional traps, a solid plug of fat forms within the trap as the fat comes into contact with the cold water held in the trap.

### 10 Does the HepvO valve make a noise?

NO - Independent tests confirm that the HepvO valve operates silently when subjected to a range of abnormal pressures.

### 11 Will HepvO encourage rats and mice to gnaw at the valve?

NO - Rats and mice gnaw to shorten and sharpen their teeth. The sealing valve of HepvO is not hard enough to encourage gnawing, neither is it attractive as a food or nesting source.

### 12 Will HepvO support microbiological growth?

NO - The materials used to manufacture HepvO will not support microbiological growth.

© HepvO is a registered trademark of Hepworth Plumbing Products

Our policy is one of constant development.

Whilst this publication is accurate at the date of printing, specification/approvals may be changed in the interest of continued improvement.